



United States Department of the Interior



MINERALS MANAGEMENT SERVICE
Minerals Revenue Management
P.O. Box 25165
Denver, Colorado 80225-0165
www.mrm.mms.gov

APR 21 2009

Dear Reporter: (Offshore Reporters Only)

This letter supersedes previous reporting instructions in the Minerals Production Reporter Handbook regarding reporting requirements for buy-back meters located in all Federal OCS waters. (Example 5-36. Offshore—Buy-back meter installed after point of sale, pages 5-140 to 5-142.)

The PASR is no longer required for buy-back meters effective the June 2009 production month.

Reporting Buy-Back on the OGOR:

When reporting buy-back scenarios, follow the enclosed examples beginning with the June 2009 production month on your OGOR. You are not required to modify your reports for prior production months. However, if you need to modify prior OGORs for a different reason, follow these new procedures.

Enclosure 1, Example 5-36 (A): Offshore—Buy-back meter installed after point of sale (buy-back volume is less than sales volume).

Enclosure 2, Example 5-36 (B): Offshore—Buy-back meter installed after point of sale (buy-back volume is greater than sales volume).

If you have questions regarding these changes, please contact your MMS company contact at 1-800-525-7922 or <http://www.mrm.mms.gov/ReportingServices/PDFDocs/operasgn.pdf>.

Sincerely,

Louise Williams
Manager, Production Accounting &
Verification Services

Enclosures



Example 5-36 (A) Offshore - Buy-back meter installed after point of sale
(buy-back volume is less than sales volume)

Key Considerations:

- With OEMM approval, part of the gas/oil measured by the sales meter is purchased (bought back) from the pipeline company and used for the benefit of the lease/agreement (for example, fuel, gas-lift, and /or pigging).

OGOR A:

- Report all wells and total production for the lease/agreement. Buy-back gas/oil should **NOT** be included in the OGOR A.

OGOR B:

- Report the volume of gas/oil subject to royalty using disposition code **01** (Sales-Subject to Royalty - Measured) or gas volume subject to royalty using disposition code **11** (Transferred to Facility). The volume of gas/oil subject to royalty is based on the volume measured by the sales meter **minus** the volume measured by the buy-back meter.
- For gas, report the volume used as fuel to operate production facilities on the lease/agreement using disposition code **20** (Used on Lease/Agreement) regardless of its origin.
- For oil, report the appropriate adjustment volume for pipeline/facility gain using disposition code **42** (Gathering System Gain or Loss).
- Enter the buy-back volume in the Comment field.

Note: The gas volume statement/run ticket for each sales meter **AND** buy-back meter must be submitted monthly to the appropriate OEMM Regional Office. The monthly gas volume statement/run ticket must be submitted even if the volume is zero.

Example 5-36 (A) Offshore - Buy-back meter installed after point of sale
(buy-back volume is less than sales volume)

Volume of gas measured by the sales meter: 10,000 Mcf
Volume of gas measured by the buy-back meter: 4,000 Mcf
Volume of gas subject to royalty: 6,000 Mcf

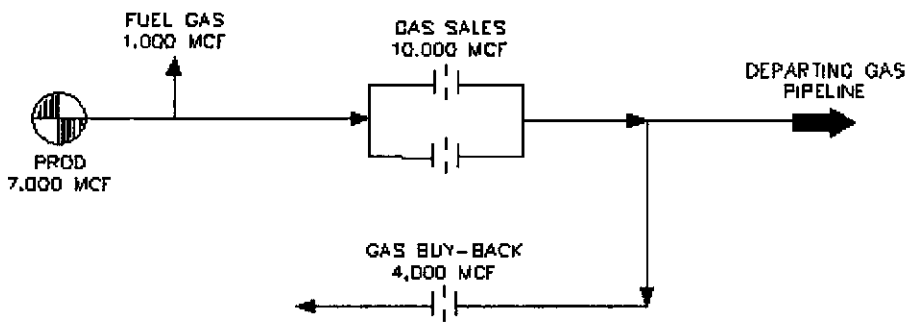

Example 5-36 (A) Offshore - Buy-back meter installed after point of sale
 (buy-back volume is less than sales volume)

OGOR Fact Sheet

Report Type	Original
Production Month	102008
MMS Operator Number	F2011
Operator Name	XYZ Company
Operator Lease/Agreement Number	OCS-G 6500
Operator Lease/Agreement Name	WC 24
MMS Lease/Agreement Number	0540065000
Agency Lease/Agreement Number	OCS-G 6500

OGOR-A Detail Information

Action Code	API	Producing Interval	Operator Well No.	Well Status Code	Days Produced	Production Volumes		
	Well No.					Oil	Gas	Water
A	177090333100	S01	A9	11	31	30	2000	10
A	177090444600	S01	A16	11	31	70	2000	80
A	177090555900	S01	A5	11	31	<u>100</u>	<u>3000</u>	<u>30</u>
TOTAL Production						200	7000	120

OGOR -B Detail Information

Action Code	Disposition Code	Metering Point No.	Gas Plant No.	API Gravity	Btu Content	Production Volumes		
						Oil	Gas	Water
A	01	20050775402		45.2		200		
A	01	3017707K00A			1072		6000	
A	20						1000	
A	27							<u>120</u>
TOTAL Disposed						200	7000	120

Authorization Information (completed on first page of each report)

Contact Name	Bob Smith
Telephone Number	5042365600
Extension Number	
Authorizing Name	Bob Smith
Date	12152008
Comment	Buy-back volume = 4,000 mcf gas

Example 5-36 (B) Offshore - Buy-back meter installed after point of sale
(buy-back volume is greater than sales volume)

Key Considerations:

- With OEMM approval, all of the gas/oil measured by the sales meter is purchased (bought back) from the pipeline company and used for the benefit of the lease/agreement (for example, fuel, gas-lift, and /or pigging).

OGOR A:

- Report all wells and total production for the lease/agreement. Buy-back gas should **NOT** be included in the OGOR A.

OGOR B:

- Report the volume of gas/oil measured by the sales meter using disposition code **09** (Sales-Not Subject to Royalty - Measured). This volume of gas/oil is not subject to royalty because the volume measured by the sales meter is less than the volume measured by the buy-back meter and royalty has been paid.
- Report disposition code **13** (Transferred from Facility) to show the volume of buy-back gas/oil brought back. Volume will be shown as a negative.
- For gas, report the total volume used as fuel to operate production facilities on the lease/agreement using the disposition code **20** (Used on Lease/Agreement) regardless of its origin.
- For oil, report the appropriate adjustment volume for pipeline/facility gain using disposition code **42** (Gathering System Gain or Loss).
- Enter the buy-back volume and state the amount is greater than the sales volume in the Comment field.

Note: In this case, the buy-back volume appears on the OGOR-B as a negative number. The gas volume statement/run ticket for each sales meter **AND** buy-back meter must be submitted to the appropriate OEMM Regional Office. The monthly gas volume statement/run ticket must be submitted even if the volume is zero.

Example 5-36 (B) Offshore - Buy-back meter installed after point of sale
(buy-back volume is greater than sales volume)

Volume of gas measured by the sales meter: 5,000 MCF
Volume of gas measured by the buy-back meter: 12,000 MCF

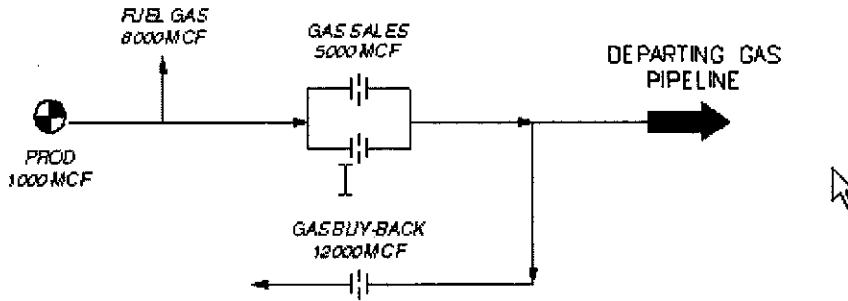

Example 5-36 (B) Offshore - Buy-back meter installed after point of sale
 (buy-back volume is greater than sales volume)

OGOR Fact Sheet

Report Type Original
 Production Month 102008
 MMS Operator Number F2011
 Operator Name XYZ Company
 Operator Lease/Agreement Number OCS-G 6500
 Operator Lease/Agreement Name WC 24
 MMS Lease/Agreement Number 0540065000
 Agency Lease/Agreement Number OCS-G 6500

OGOR-A Detail Information

Action Code	API Well No.	Producing Interval	Operator Well No.	Well Status Code	Days Produced	Production Volumes		
						Oil	Gas	Water
A	177090333100	S01	A9	11	31	30	200	15
A	177090444600	S01	A16	11	31	70	500	80
A	177090555900	S01	A5	11	31	<u>100</u>	<u>300</u>	<u>30</u>
TOTAL Production						200	1000	125

OGOR -B Detail Information

Action Code	Disposition Code	Metering Point No.	Gas Plant No.	API Gravity	Btu Content	Production Volumes		
						Oil	Gas	Water
A	01	20050775402		45.2		200		
A	09	3017707K00A			1072		5000	
A	13						(12000)	
A	20						8000	
A	27							<u>125</u>
TOTAL Disposed						200	1000	125

Authorization Information (Completed on first page of each report)

Contact Name Bob Smith
 Telephone Number 5042365600
 Extension Number
 Authorizing Name Bob Smith
 Date 12152008
 Comment Buy-back volume = 12,000 mcf gas (greater than sales volume).